

2-Axis Magnetic Field Sensor

PS-2162

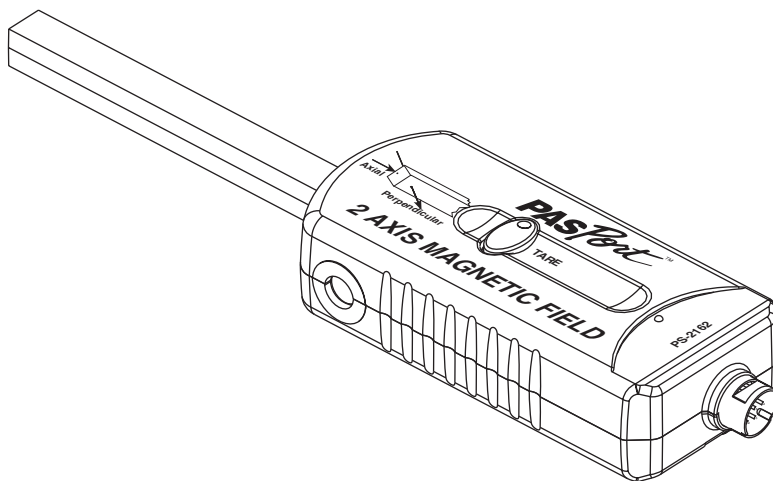

Included Equipment	Part Number
2-Axis Magnetic Field Sensor	PS-2162
PASPORT Extension Cable	PS-2500
Sensor Handle	648-08372
Required Equipment	
PASPORT Interface ¹	See PASCO catalog or www.pasco.com
Optional Equipment	
Zero Gauss Chamber	EM-8652

¹Compatible PASPORT interfaces include the Xplorer (PS-2000), Powerlink (PS-2001), Xplorer GLX (PS-2002), USB Link (PS-2100), and others. See the PASCO catalog, visit www.pasco.com, or contact PASCO tech support for more information.

Introduction

Use the PASPORT 2-Axis Magnetic Field Sensor in conjunction with a PASPORT interface to measure magnetic field strength simultaneously along two perpendicular axes.

The sensing elements are two Hall Effect devices oriented perpendicularly to one another and located at the end of the sensor's probe. The sensor measures the magnetic field in the **Axial** and

Perpendicular directions as illustrated. Two white dots on the probe mark the positions of the sensing elements.

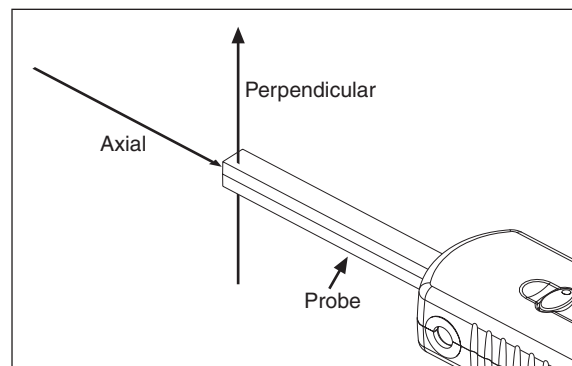

Setup

Connect the sensor to a PASPORT interface, either directly or using the included extension cable. If you will be using a computer, connect the interface to it and start DataStudio or EZ-Screen software.

Optional: If you have a zero-gauss chamber (part EM-8652), insert the probe into the chamber and press the Tare button on the sensor to zero both measurements. For greatest accuracy, tare the sensor in this way after it has been connected to a powered interface for a few minutes.

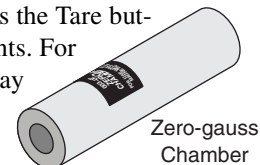

Note: If you do not have a zero-gauss chamber, pressing the Tare button may result in a small offset to subsequent measurements due to the earth's magnetic field. To "undo" the tare, briefly disconnect the sensor from the interface.

Measuring Magnetic Field

In the software or on the interface, start data collection to begin recording magnetic field strength along both axes in units of gauss (G). Position the sensing elements (marked by white dots) at the location to be measured and orient the sensor with the field lines.

Note: For more information about using your PASPORT interface, refer to the documentation that came with it. For instructions on using DataStudio, press F1 or open the Help menu.

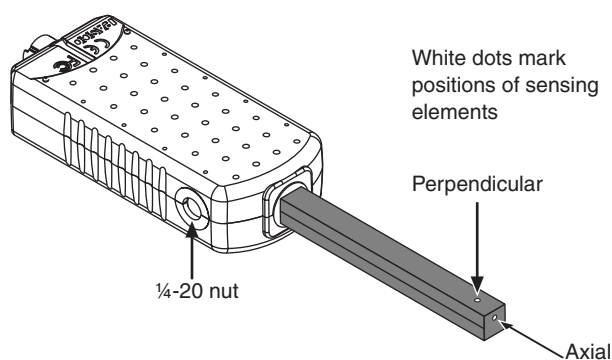

Resolution and Sampling Rate

The sensor uses dynamic variable over-sampling to achieve the best resolution possible for a given sampling rate. At the default sampling rate of 10 Hz, the resolution is 0.01 G. To improve the resolution, set a lower sampling rate in the software or on the interface. The best resolution occurs when sampling at 1 Hz or slower.

Hardware Mounting

The sensor includes a captured 1/4-20 nut, which you can use to fasten it to the included sensor handle, a rod, or other apparatus. The sensor handle can be used to mount the magnetic field sensor on a rotary motion sensor (part PS-2120). With the sensor mounted in this way, it may be necessary to use the included extension cable to connect the interface.

Suggested Activities

Earth's Magnetic Field

Set the sampling rate to 5 Hz. Start data collection and slowly rotate the sensor while observing Axial and Perpendicular field

strengths on a graph display. As you change the angles of the sensing elements relative to the earth's field, you will see the measurements vary.

For a more quantitative study, use the included sensor handle to mount the magnetic field sensor on a rotary motion sensor (part PS-2120) and record field strength as a function of angle.

Magnetic Field of a Coil

Use the sensor to measure the field of a coil as a function of current through the coil or position within the coil. Rotate the sensor to find the direction of field lines at various locations near the coil.

Specifications

Range	±1000 G
Accuracy	5% of reading @ 25 °C after 4 minutes' warm-up and Tare using zero-gauss chamber
Resolution	0.01 G @ 10 Hz sampling rate
Maximum Sampling Rate	1000 Hz
Repeatability	0.05%

Technical Support

For assistance with any PASCO product, contact PASCO at:

Address: PASCO scientific
10101 Foothills Blvd.
Roseville, CA 95747-7100

Phone: 916-786-3800 (worldwide)
800-772-8700 (U.S.)

Fax: (916) 786-7565

Web: www.pasco.com

Email: support@pasco.com

Limited Warranty

For a description of the product warranty, see the PASCO catalog.

Copyright

The PASCO scientific 012-09324B *2-Axis Magnetic Field Sensor Instruction Sheet* is copyrighted with all rights reserved. Permission is granted to non-profit educational institutions for reproduction of any part of this manual, providing the reproductions are used only in their laboratories and classrooms, and are not sold for profit. Reproduction under any other circumstances, without the written consent of PASCO scientific, is prohibited.

Trademarks

PASCO, PASCO scientific, DataStudio, and PASPORT are trademarks or registered trademarks of PASCO scientific, in the United States and/or in other countries. For more information visit www.pasco.com/legal.